



## SQS65 Series Electronic Valve Actuator

### Product Description

The SQS actuator requires a 24 Vac, Class 2, supply and a 0 to 10 Vdc signal to control Powermite 599 Series terminal unit valves with 7/32-inch (5.5 mm) stroke.

### Warning/Caution Notations

<b>WARNING:</b>		Personal injury/loss of life may occur if you do not perform a procedure as specified.
<b>CAUTION:</b>		Equipment damage, or loss of data may occur if you do not follow the procedures as specified.

### Product Number

SQS65U – Non-spring Return (Fail-in-place actuator)

SQS65.5U – Spring Return (Fail-safe actuator)

### Required Tools

- 1-1/4-inch open end wrench
- #2 Phillips or flat-blade screwdriver
- Flat blade calibration screwdriver (3 mm) for wiring connections
- Wire cutter/stripper

### Estimated Installation Time

- 12 minutes for wiring a factory installed actuator.
- 30 minutes for field replacement of actuator.

### Prerequisites



#### WARNING:

If mounting the actuator to a valve already in line, either close the shut-off valves in the piping (upstream first, then downstream) or switch off the pump to allow the differential pressure in the valve to drop.



#### WARNING:

Disconnect the controller power before replacing the actuator.

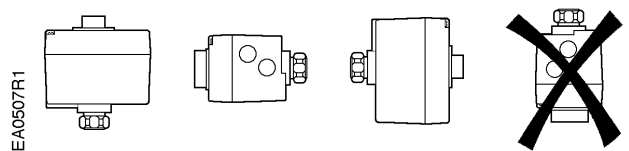

Figure 1. Acceptable Vertical Mounting Positions.

### Instructions

If you are mounting an actuator on a new valve, begin with the instructions, *Mounting an Actuator to a Valve*.

#### Remove Actuator from Valve

1. Remove the actuator cover using either a #2 Phillips or a #2 flat blade screwdriver.
2. Disconnect and identify the wires. Place the cover back on the actuator.
3. Use a 1-1/4-inch open end wrench to loosen the coupling piece.
4. Remove the actuator from the valve.

## Mounting an Actuator to a Valve

1. If you are attaching the actuator to a new valve, remove the protective plastic cap from the valve stem.
2. On the SQS65U actuator, turn the manual-positioning knob to "0".
3. Place the actuator on the valve.
4. Use a 1-1/4-inch open-end wrench to tighten the coupling piece.
5. Use either a Phillips head screwdriver or a flat-blade screwdriver to remove the actuator cover for access to the terminal block, selector plug, and jumper wire.
6. Attach wires, set the selector plug and if necessary, cut the R–M jumper. See *Wiring and Start-Up*.
7. Place the cover on the actuator. The positioning knob must be at "0" to fit into the shaft. If the cover does not fit easily, turn it 180 degrees.
8. Fasten the cover with the screws.

## Wiring

All wiring must conform to NEC and local codes and regulations.

Use earth ground isolating, step-down Class 2 transformers. Do not use auto transformers.

Determine the supply transformer rating by adding the total VA of all actuators used. The maximum rating for Class 2 step-down transformer is 100 VA. It is recommended that no more than 10 actuators be powered by one transformer.

To use a 0 to 1000 ohm input signal on terminal R, the circuit board jumper R–M must be cut.



### CAUTION:

If the circuit board jumper R–M is cut, you cannot wire the R and M terminals on the terminal block to re-establish the connection.

Use a jumper wire between R–M to re-establish default functionality.

The 0 to 1000 ohm signal is additive to the 0 to 10 Vdc control signal. For example, a controller commanded to 2 Vdc (20%) plus a remote override input to 300 ohms (30%) results in a position of 50% stroke.

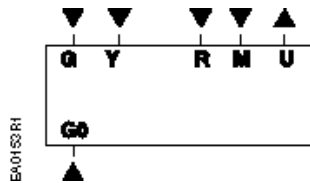

Figure 2. Terminal Connections of the SQS65U Series

Do not power more than 10 actuators with one transformer. (Use 0.5 amp on secondary actuator.)

G, G0	24 Vac operating voltage
G	System potential
G0	System neutral
Y	0 to 10 Vdc control signal
R	Input for 0 to 1000 Ohm remote setting unit or low temperature detection unit
M	Measuring neutral
U	Output for 0 to 10 Vdc position indication

### WARNING:



Terminal connection G is 24 Vac HOT, not ground.

### CAUTIONS:



- G0 and G must be properly wired for correct function and full life of the actuator.
- If the actuator makes a buzzing noise upon reaching setpoint, G and G0 are improperly wired and should be reversed.

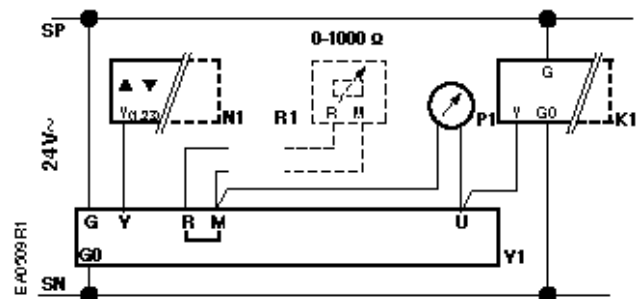

Figure 3. Wiring for Applications.

K1	On/Off switch	P1	Indicating unit
N1	Controller	R1	Remote setting unit
Y1	Actuator		0 to 1000 Ohm

- The diagram shows all possible connections. The application determines which connections are used.
- All units connected to terminals Y and U, together with the SQS 65U must be connected to the same G0.

## Start-Up

1. Set the selector plug for the recommended flow characteristic.
2. To change the jumper setting, remove the actuator cover and move the selector plug. See Figure 4.

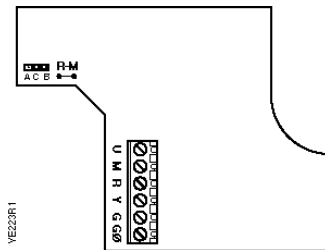
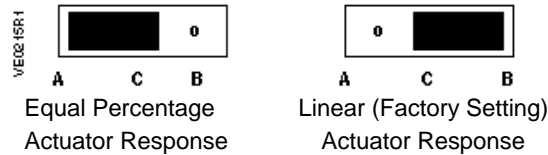

Figure 4. Location of the Terminal Strip, Selector Plug, and R-M Jumper on the Circuit Board.

Table 1. Setting for Recommended Flow Characteristic.

Valve Action	Recommended Setting for Selector Plug
N C Steam	C-B
N C Liquid	C-B
N O	C-B

## Manual Override for SQS65U Non-Spring Return

Turn Manual Positioning Knob **clockwise** to move actuator coupling piece outward. See Figure 5.

Turn Manual Positioning Knob **counterclockwise** to move actuator coupling piece inward. See Figure 5.

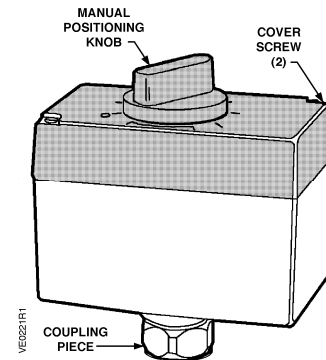

Figure 5.

## Troubleshooting

- Check wiring for the proper connections.
- Check selector plug for recommended position.

## References

EA 599-8, Powermite 599 Series SQS Electronic Valve Actuator Proportional Control Technical Instructions, Document Number 155-190P25

## Dimensions

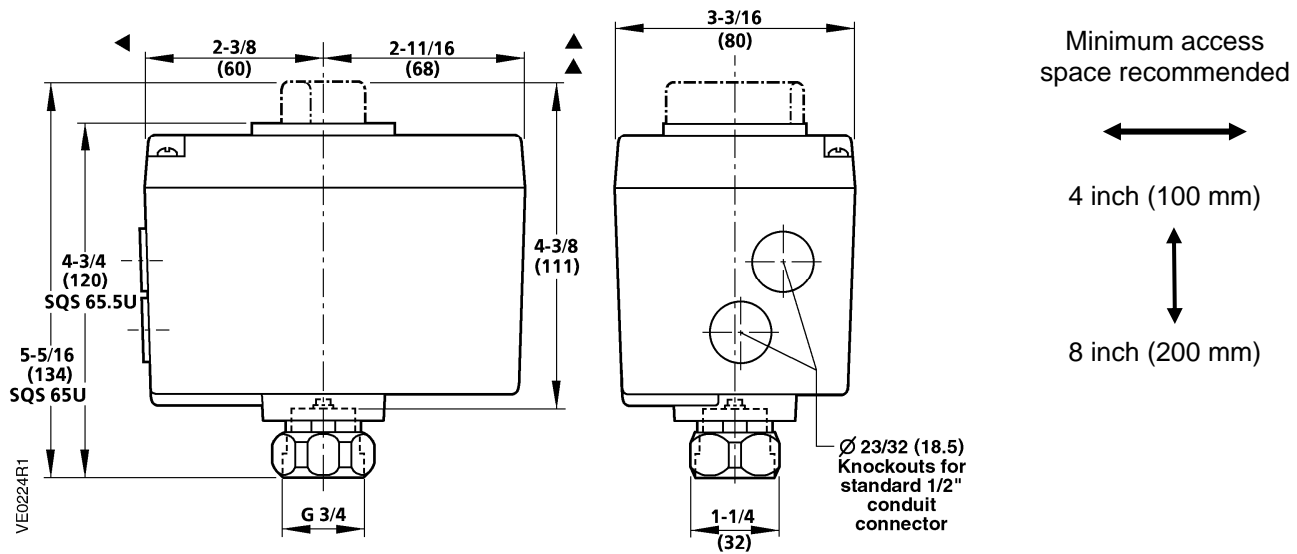

Figure 6. SQS65U Dimensions in Inches (Millimeters).

Information in this publication is based on current specifications. The company reserves the right to make changes in specifications and models as design improvements are introduced. Product or company names mentioned herein may be the trademarks of their respective owners. © 2009 Siemens Industry, Inc.